

# Wattman

**& Wattman Link**

User manual





**Please read this user manual carefully.**

We would like to thank you for choosing a PESS Energy product and we hope that you will enjoy using your device in your daily work.

If in spite of this manual, you encounter any misunderstandings or situations that have not been mentioned in this document, please contact us by e-mail at [contact@pessenergy.com](mailto:contact@pessenergy.com) or by telephone on +334 91 58 86 74. Please read all the instructions in this manual carefully.

Follow all warnings and information contained in this manual. PESS Energy cannot be held responsible for any damage or injury caused by incorrect use. This user manual applies to the Powerbank Wattman, referred to as 'the device'.

In order to continuously improve our products and ensure customer satisfaction, we reserve the right to make technical changes to the device without prior notice.

For more information about our company and our products, you can find us on our official website [www.pessenergy.com](http://www.pessenergy.com).

## Table des matières

<b>I. Use cases illustrations</b> .....	<b>4</b>
<b>II. Instructions</b> .....	<b>8</b>
1. General safety instructions.....	8
2. Important instructions for the environment .....	9
<b>III. Device presentation</b> .....	<b>10</b>
1. General characteristics of the device.....	10
2. Technical characteristics of the device .....	10
3. Basic System Architecture.....	13
<b>IV. Getting started with the device and using it</b> .....	<b>16</b>
1. Before powering on.....	16
2. Using the device.....	16
a. Getting Started.....	16
b. Powering your electrical equipment .....	16
c. Shutting down the device .....	17
d. Operating and recharging temperatures .....	17
e. Automatic starting of a gas generator .....	18
f. Electrical overload or leakage.....	19
g. Device failure.....	19
h. Long-term device storage.....	19
i. Maintenance .....	19
3. Recharging the device .....	20
a. Recharging the device from the grid .....	20
c. Recharging the device on photovoltaic panels.....	20
d. Recharging the device at an electric car charging station.....	21
4. Transport of the device.....	22
<b>V. FAQ</b> .....	<b>23</b>
1. Why is there no power in the sockets? .....	23
2. Why don't the screens light up?.....	23
<b>VI. Repairs and warranty interventions</b> .....	<b>24</b>
a. Warranty Repairs.....	24
b. Out-of-warranty repair.....	24
c. Warranty Exclusions.....	24
d. End of life of the device.....	24
<b>VII. Cases of misuse of the device</b> .....	<b>25</b>
<b>VIII. Exclusions from use</b> .....	<b>26</b>

# I. Use cases illustrations

Moving



! heavy lifting  
90 kg

Climbing stairs



Carrying

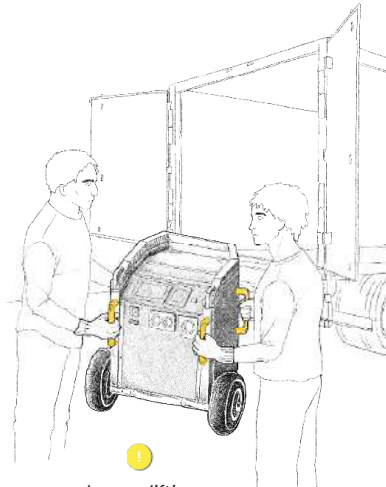

! heavy lifting  
90 kg

Transport

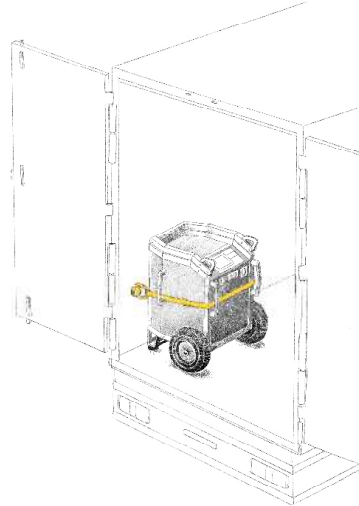

## Back-up mode

*In case of grid failure, Wattman takes over*

- 1 Wattman must be 100% charged before being connected to the mains.

Switch time : 20ms

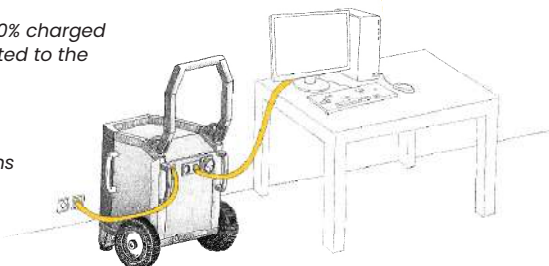

## Daisy chain

- 1 All devices must be fully charged first, risk of overcharging

32A cable available as accessory

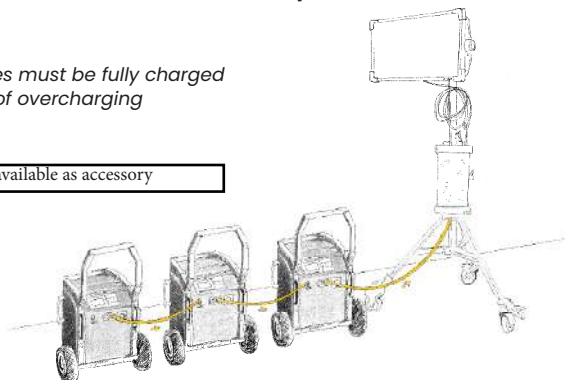

## Wattman recharging on a domestic socket

*Do not plug 2 Wattman into the same domestic socket*

*Do not charge and discharge at the same time*

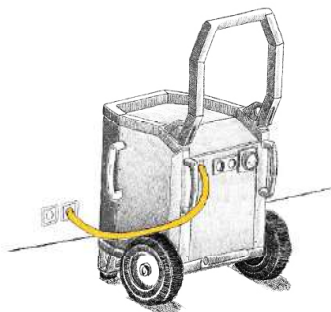

Recharge >4h  
charge power : 3600W

## Power your equipment

- 1 Output : 6000W max

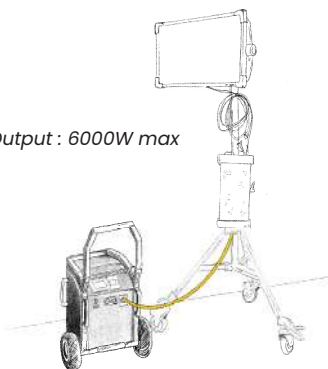

## Team Work with 2 Wattman

Optional accessory InfiniT  
Output : 6000W  
Capacity : 20 000Wh

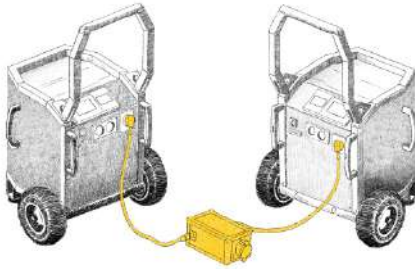

## Team Work with 2 different power supplies

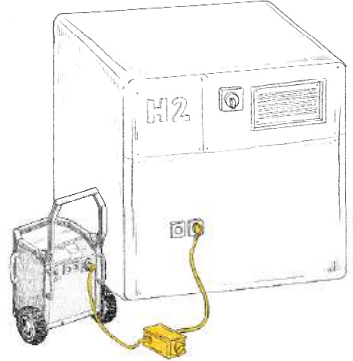

Switch time : 0.6 s

## Recharging on an Electric Vehicle charger

Option : Kit EV-adapter  
Recharge 6 Wattman in less than 4h

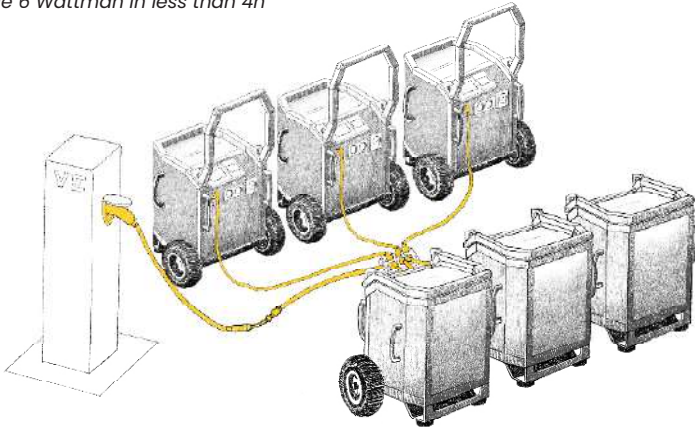

## Wattman recharging on an Ekla kit (solar panels)

Output: up to 6000W

Capacity: 18 800Wh\*

(10 000 Wh for the Wattman and 8 800Wh/day produced by Ekla)

Charge time for a Wattman: < 12 hours\*

\*Depends on weather, season and location

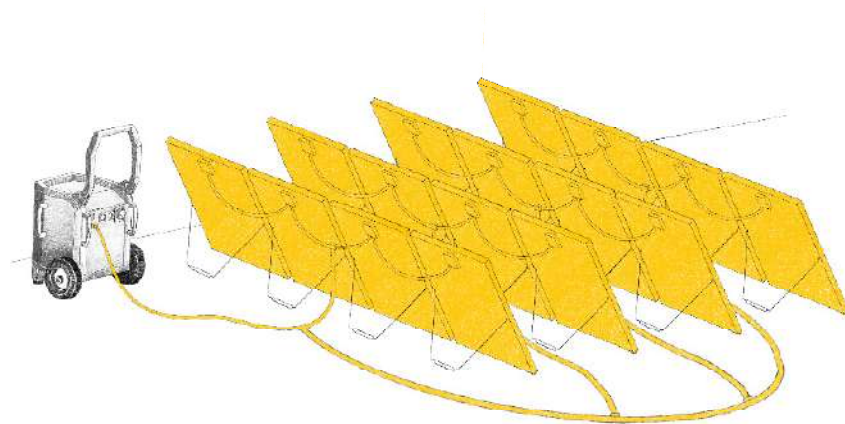

## II. Instructions

### 1. General safety instructions

- This device generates electricity on a private network, under the responsibility of the user. Only qualified personnel may use this device.
- For optimal and safe operation of the device, please follow the required specifications on the electrical power of your devices to be powered.
- Equipment with a combined continuous electrical power of more than 11 000 W must not be connected to the device.
- If you wish to disconnect the AC or DC terminals, please follow the operating procedure carefully (*see section IV.2 'Starting up the device'*).
- Neutral system :
  - TN-S for mobile use : Before any use, the device must be earthed using an earth rod.
  - TT for grid use : the device is earthed to the mains socket via its charging cable. Make sure you comply with local requirements and applicable regulations when installing the device.
- The device must be stored charged at a temperature between -20°C and +50°C, in a dry, ventilated, clean area away from direct sunlight.
- The photovoltaic (PV) input is a maximum of 5500 W (MPPT from 90 to 450 VDC – 500 Voc) (*see III.2 'Technical characteristics of the device'*).
- When not in use, the device must be switched off by pressing the 'POWER' button. (*see IV.3 'Switching off the device' & III.3 Figure 1 and 2*).
- Do not use the device when it is completely discharged.
- Do not immerse the device.
- **The emergency power cut also marked 'Emergency off switch' on the device** (*see III.3 Figure 1*) **must only be used in the following cases :**
  - ◇ Smoke and/or fire emanating from the device (use only if possible).
  - ◇ Long-term storage of the device (more than 2 days).
  - ◇ In the event of a device fault (*see section V.1.Figure 5: Start-up procedure in the event of a fault*)
  - ◇ Problem caused by equipment connected to the device.
  - ◇ During a maintenance procedure.

- It is forbidden to connect electrical equipment to the output of the device during charging to a 16A mains socket (risk of INPUT and mains overload) with the exception of Daisy Chain (see IV.4.a).
- Do not open the device (**risk of electric shock, loss of manufacturer's warranty**). Repairs may only be carried out by repairers authorised by PESS Energy. If any faults remain after repair, please return your device to the authorised PESS Energy repair centre or to the retailer who sold it to you.
- Do not short-circuit any of the device's inputs or outputs.
- Do not connect 2 output sockets to each other.
- Do not connect an output socket to the device's charging socket.
- Do not connect an output socket to a PV input socket on the device.
- Do not cover the device when in use (unless using the optional rain cover supplied by PESS ENERGY)
- When in use, the device should be kept in the shade.
- The device must not be exposed to rain (unless using the optional rain cover supplied by PESS ENERGY)
- It is forbidden to climb on the device.
- It is forbidden to use the handlebars (see III.3.Figure 1) of the device as a lifting point.
- The device must be handled with care.
- The device must only be lifted using the handles.

## 2. Important instructions for the environment

- PESS Energy is responsible for the end-of-life and recycling of the product.
- This device must not be disposed of with other waste in order to prevent possible damage to the environment or human health. Contact the retailer who sold it to you in order to recycle it responsibly and safely.
- The cardboard packaging and wooden pallet support that protect the device during transport can be recycled. They should be discarded in the appropriate containers. Other plastic waste should be discarded in the rubbish bin.

### III. Device presentation

This device is a mobile energy unit, combining inverter, solar charger and battery charger functions to provide uninterrupted power supply. Its LCD screen allows the user to control the device's functions and easily access information such as the battery's state of charge, temperature, error messages and the device's input and output power.

#### 1. General characteristics of the device

- Integrated 6000W max continuous 230 Vac - 50Hz inverter.
- Integrated battery charger.
- MPPT : Integrated solar charge controller - 5500W max continuous.
- Compatible with 230VAC mains voltage or a 170–280VAC generator.
- Protection against overloading, overheating and short circuits.
- System pre-heating function

#### 2. Technical characteristics of the device

Technical data		WATTMAN
AC Production <sup>1</sup>	Rated Power	6000 W
	Peak power	10.8 kW for 0.1 s; 7.2 kW for 5 s; 6.6 kW for 10 s
	Battery capacity	10 000 Wh
	AC output voltage	230 VAC ±5%
	Frequency	50 Hz
	Signal type	Pure sinus
	Switching time	10ms (for personal computers) / 20ms (for domestic equipment)
Connections	AC output connections (OUTPUT)	2x single-phase sockets 16A 1x single-phase socket 32A
	AC input connections (INPUT)	1x Input Power Twist NAC3 (20A) 1x Input Neutrik 32A (NAC3MPHC) <a href="#">(option Wattman Link)</a>
	DC input connections (SOLAR)	1x Anderson 50A
	Dry contact <a href="#">(option Wattman Link)</a>	1x SpeakON 4P socket - Automatic generator set start

<sup>1</sup> At room temperature (20°C).

<b>Recharge</b>	AC Power supply	230 VAC 50 Hz
	Max charging power AC socket 16A	3600 W
	Recharging time (if empty)	< 4 hours on a 16A socket
	Max recharging power AC socket 32A (option Wattman Link)	<i>3600W for Daisy Chain at full power + simultaneous charging and recharging possible up to 3600W</i>
	Recharging time (if empty)	< 4 hours on a 32A socket
<b>Protection</b>	AC Protection	Differential Switch 30mA (40A)
	AC Circuit breaker	2x 16A circuit breaker 1x 32A circuit breaker
	DC Emergency off switch	Punch button
	DC Protection (Battery)	Fusible magnéto thermique 200 A / BMS
	DC Protection (PV)	Fusible magnéto thermique 2 P – 40 A / Disjoncteur 40 A DC
	Earthing	Earth rod
<b>Battery</b>	Battery chimie	NMC
<b>Solar panels</b>	Max PV Power	6000 W
	MPPT Voltage Range	120 VDC - 450 VDC
	Integrated Maximum Power Point Tracking (MPPT)	
	PV max current	40 A
<b>Use time</b>	Use time at 300W	> 32 h
	Use time at 500W	20 h
	Use time at 1000W	10 h
	Use time at 2000W	5 h
	Use time at 3000W	> 3 h
	Use time at 4000W	2 h 30



<b>Temperatures</b>	Recharge temperature <sup>1</sup>	-20 ~ +50 °C
	Use temperature <sup>2</sup>	-10 ~ +50 °C
	Storage temperature	0 ~ +45 °C
<b>Physical</b>	Dimensions (H x L x l)	68 x 53 x 64 cm
	Net Weight	90 kg
<b>Environnement</b>	Protection class	IP 23, IK 08
	Certifications	CE - UN 38.3
	Manufacturer's warranty	2 years
	EMC class	Class A / Pollution degree: 3
	Diversity factor (RDF)	1
	Maximum altitude	2000m
	Relative humidity	Max 100% at 25°C non-condensing

1 Between -20 °C and +5 °C the device does not charge but activates its preheating system. Please follow the procedure for switching the device on once the minimum temperature of 5°C has been reached.

2 Refer to IV.2 for details of how to start up the device in the various situations identified.

### 3. Basic System Architecture

The following illustration shows the basic functions of the device, which can be used as an electrical power source and/or solar power generator.



Contact PESS Energy for other possible system configurations, depending on your needs. This device can power all types of home or professional devices, including motorized devices such as lights, vacuum cleaners, Led panels, compressors, etc.



- |                                     |   |
|-------------------------------------|---|
| <b>1</b> Power                      | <b>6</b> INPUT solar panel socket<br>Anderson - 50A (6000W max) |
| <b>2</b> Control and charge screens | <b>7</b> Emergency off switch                                   |
| <b>3</b> INPUT AC 20A               | <b>8</b> Reset button   |
| <b>4</b> 2x OUTPUT 230 VAC - 16A    | <b>9</b> Power circuit breakers<br>40A - 30mA                   |
| <b>5</b> 1x OUTPUT 230 VAC - 32A    | <b>10</b> Vents   |

*Figure 1: Connector layout and key elements*



Figure 2: Layout of additional Wattman Link connectors (optional)

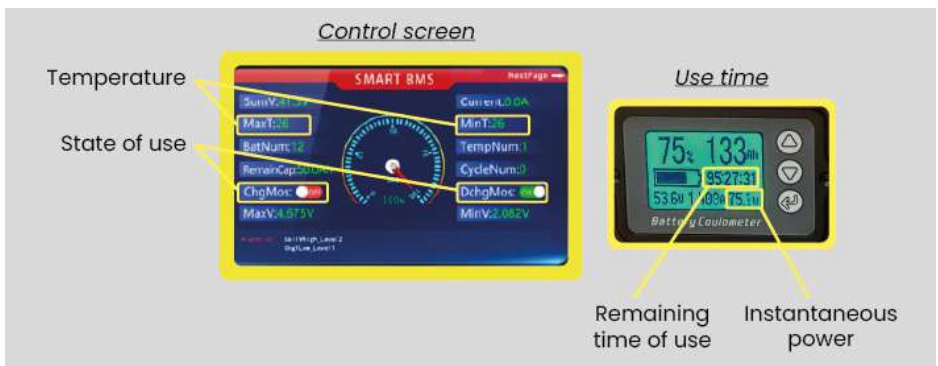

Figure 3: Zoom on screens

## IV. Getting started with the device and using it

### 1. Before powering on

- Make sure that the air intakes (see III.3. Figure 1) of the device are not obstructed.
- Connect the device to the ground using an earth stake (see III.3. Figure 1).
- The device can be operated standing or lying on its front (sockets facing upwards).

### 2. Using the device

Throughout the duration of use of the device, monitor the device's charge levels and the remaining time of use (on the charge level screen) not to be surprised by the shutdown of the device and to anticipate its recharging.



**Do not connect too many devices at the same time (max 6000W continuous), which will cause the device to overload and fail.**

In the event of exposure to excessively extreme temperatures, beyond the ranges specified in III.2 «Technical characteristics of the device», the device will stop to get to safety.

#### a. Getting Started

For the location of the buttons, refer to III.3 Figure 1.

1. Ensure that the emergency off switch button is in the «pulled» position and the circuit breakers and differentials are in the ON position (Up position).
2. Press the «Power» button to start the powerbank.
3. The LED on the «Power» button illuminates when there is power on the output sockets.

#### b. Powering your electrical equipment

Connect your devices to the AC sockets of the device, making sure that the maximum electrical power of your equipment does not exceed the maximum power of the device (6000 W).

Check that the device is working. The value displayed on the charge level display must not exceed 6000 W (see III.3. Figure 3) and control the remaining time of use.

- ! **Never unplug an electric device while in use. Be sure to turn off your power-consuming equipment before unplugging. Never exceed the maximum allowable current through the output outlets.**

### **c. Shutting down the device**

- 1) Turn off the device by pressing the «POWER» button, the white light of the device will then turn off.
- 2) Check that the screens turn off (this can take up to 30sec).
- 3) Unplug all your equipment

- ! **The emergency off switch button must be held in the «pulled» position. It must only be positioned in the «pushed» position in the special cases mentioned in III.1 «General safety instructions»; transport and shut down of the device are excluded. Abusive and improper use of the device may cause the device to malfunction.**

### **d. Operating and recharging temperatures.**

The powerbank is normally used within a temperature range of between 5°C and 50°C. Outside this temperature range, there are special cases of use.

#### **◆ Recharging**

Below 5°C, recharging is blocked to preserve battery life. A pre-heating system is automatically activated as soon as the device is connected to a 220-240V power source and the battery temperature is below 23°C. No action is required on the part of the user.

Recharging starts once the batteries are above 5°C. If it does not start immediately, disconnect the power supply, press ON/OFF, then reconnect. Check on the display that there is an incoming current.

The heating system uses the energy from recharging, without drawing on the batteries. Its consumption is additional to that of recharging and varies from model to model.

## ◆ Discharging

Between  $-10^{\circ}\text{C}$  and  $5^{\circ}\text{C}$ , the powerbank can be used as long as it does not exceed 30% of its maximum power. The power can be increased once the temperature of the batteries exceeds  $5^{\circ}\text{C}$ . Using full power in this range reduces the life of the device.

Below  $-10^{\circ}\text{C}$ , a protection system blocks operation until the temperature returns to an acceptable level.

### **e. Automatic starting of a gas generator (option [Wattman Link](#))**

The «Dry Contact» socket is a SpeakON 4P socket. 2 poles allow you to trigger the start automatically. See the following wiring diagram.

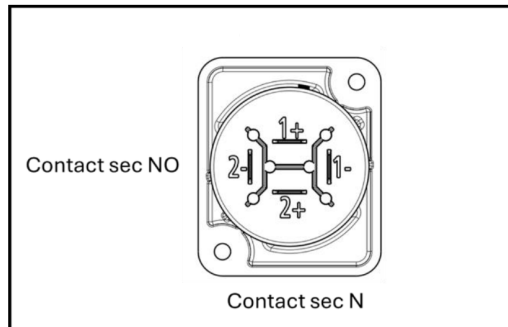

- Wire a 32A output of your gas generator to the 32A input socket of the Flywatt.
- Also connect the dry contact cable to the starter motor and the charging of the starter battery of your gas generator.
- Turn on your Flywatt to power your electrical loads.

**When the Flywatt approaches 0%, the external generator will start automatically.**

## **f. Electrical overload or leakage**

In the event of an overload, check your electrical installation, turn the device off and on again by pressing the «POWER» button. If necessary, contact PESS Energy.

In both cases (overload or electrical leakage), the device goes into safety. As soon as possible, you should disconnect all cables (in and out) and check the ground connection of the device and your equipment(s) if necessary. If the device is working properly, make sure that the equipment plugged into the device does not have any electrical faults or insulation.

Then reset the differential switch. If the differential breaks again, contact PESS Energy.

## **g. Device failure**

If the device does not start or if it switches off prematurely, contact the retailer the retailer who sold it to you.

## **h. Long-term device storage (more than 2 days)**

- Store the charged device.
- Push the emergency off switch button to turn off the power.
- It is recommended to store the device at a temperature between 0 and 35°C, in a dry, ventilated, clean and dark area.

## **i. Maintenance**

- Cycle (complete charge and discharge) of the battery at least once a month.
- Check sockets, charging cables and ground stakes.

### 3. Recharging the device

#### a. Recharging the device from the grid

First connect the cable to the «INPUT AC» charging port of the device, then the mains socket (230VAC, 16A or 32A socket) using only the cable supplied with it (see III.3. Figure 1).

Check that the device starts recharging :



- ◇ The value displayed on the charge level screen should not exceed 3600W at 16A and 32A ([Optional 32A charging cable - Wattman Link](#))
- ◇ The green color of the charge level screen
- ◇ should appear and then disappear cyclically.

In the event of exposure to temperatures that are too extreme, beyond the ranges specified in III.2 «Technical characteristics of the device», the device will not be able to charge and will be safe.

- ⚠ Do not connect the 2 INPUT sockets at the same time.
- ⚠ When fully charged, first unplug the AC outlet and then the cable from the device's «INPUT AC» charging port.
- ⚠ Do not let the device to charge unattended.
- ⚠ The 'SumVHigh\_Level1' alert appears on the screen when the batteries are 100% charged.  
The 'SumVlow\_Level1' alert appears when the device needs to be recharged.

#### c. Recharging the device on photovoltaic panels

- ⚠ The photovoltaic installation must be sized within the limits of the power allowed by the device, as specified in III.2 «Technical characteristics of the device». A total voltage of the solar installation below 90VDC will not trigger charging. A voltage higher than 450VDC may degrade the device.

- 1) Lower/position the «PV IN» circuit breaker to «OFF» (see III.3. Figure 1) before connecting the PV system
  - 2) Make sure the emergency off switch button is in the «pulled» position
  - 3) First connect the Anderson solar panel socket to the device (see III.3. Figure 1) and then connect your photovoltaic installation
  - 4) You will only be able to raise the «PV IN» circuit breaker when your installation is connected (see previous steps).
- Charging starts automatically.
  - The value displayed on the charge level screen must not exceed 6000W.
  - It is possible to use the device while recharging on solar panels.
-  **Do not handle the Anderson solar panel plug when the PV IN circuit breaker is raised/set to «ON».**
-  **Do not allow the device to charge unattended.**

When the recharge is complete, turn the circuit breaker down to «PV OFF» and then disconnect your solar installation before handling the device's Anderson plug.

For further information, please refer to the user manual of the EKLA kit (PESS Energy PV solution).

#### **d. Recharging the device at an electric car charging station**

-  **The use of an EV adapter (type 2 plug) is required (available in option). Carefully follow the instructions in the EV adapter's user manual.**

#### 4. Transport of the device

- The device can be carried upright or lying on its front (with the sockets facing upwards).
- The device must be adequately secured to the transport vehicle when it is being moved. To do this, use a number of straps which must be positioned on the reinforcements of the device (*see I. 'Illustrations of use'*).
- The device must be turned off before transport by pressing the «POWER» button.
- The circuit breakers of the device must be lowered/in the «OFF» position for the duration of transport.
- If you accidentally press the 'Lightboard' button when packing the device for transport, the screens may remain lit even though the device is switched off. They will switch off automatically after a few seconds.
- The transport and/or shipment of the product by the user may be subject to the mandatory provisions governing the transport of hazardous materials (lithium ion batteries contained in equipment – UN3481). For more information, consult the Product Safety Data Sheet and/or contact your freight forwarder.



**The emergency off switch button must be held in the «pulled» position. It must only be in the «pushed» position in the special cases mentioned in III.1 «General safety instructions»; transport and stopping of the device are excluded. Abusive and improper use of the device may cause the device to malfunction.**

## V. FAQ

### 1. Why is there no power in the sockets?

- Check that the circuit breakers are in the «ON» position.
- Check that the emergency off switch button is pulled correctly.

### 2. Why don't the screens light up?

- Check that the emergency off switch button is pulled.
- It may take up to 10 seconds for the screens to turn on.
- The device may have run out of battery, plug it into a mains socket and check that it is turned on.

## **VI. Repairs and warranty interventions**

The devices are warranted for 2 years, parts and labor, from the date of shipment from the PESS Energy production site, only for European Union countries (Schengen Area), excluding French overseas departments and territories.

### **a. Warranty Repairs**

Any failure not resulting from misuse and occurring within 2 years of the date of shipment of the device may be repaired under the manufacturer's warranty. The location of warranty repair will be decided based on the analysis of the breakdown that will be communicated by the customer.

Repairs under manufacturer's warranty (spare parts and labour) are covered by PESS Energy.

### **b. Out-of-warranty repair**

Any breakdown occurring beyond the 2 years of the manufacturer's warranty may be repaired by an approved repairer, or if necessary PESS Energy, at the expense of the customer, on the basis of intervention estimates that may be proposed to him, before intervention.

### **c. Warranty Exclusions**

PESS Energy cannot be held responsible for a defect (breakdown or wear and tear) if it results from improper use of the device. In this case, the repairs and warranty of the device may also be cancelled.

### **d. End of life of the device**

Regarding the disposal of your device at the end of its life, please refer to II.2 «Important instructions for the environment».

## VII. Cases of misuse of the device

- Opening the device is not allowed.
- Shocks, punctures, falls (noticeable damage to the chassis or trims).
- Water penetration, immersion, humidity greater than 95%.
- Excessive dust.
- Storage out of the temperature range.
- Use outside the temperature range.
- Short circuit of the input and output sockets.
- Extended storage of unloaded equipment.
- Overloading of the device's inputs and/or outputs.
- Changed the factory computer settings.
- Installation of components not approved by the manufacturer.
- Use in the event of an exclusion of use (see VII «Exclusions of use»).
- The product must not be used :
  - In ATEX environments
  - In nuclear environments
  - In the mining industry
- Do not recharge the device with a cable not supplied by PESS energy.

**Misuse of a device will result in a total suspension of the manufacturer's warranty.**

## VIII. Exclusions from use

In addition to the «Safety Instructions» given in III, it is forbidden to :

- Climb onto the device.
- Lift the device more than one metre off the ground.
- Drop the device.
- Pierce the device.
- Insert foreign objects into the device.
- Short circuit in and around the device.
- Set the device on fire.
- Driving over a person, or fragile ground with the device.
- Spray the device with water or any other liquid, or immerse it.
- Store the device discharged.
- Store the device outdoors for a long time (>2 days).
- Dispose of the device in nature.
- Transporting the device in an inappropriate vehicle.
- Transport of the device badly strapped.







Find all the technical  
documentation here



**PESS ENERGY** *PILLOT ENERGY STORAGE SOLUTION*

 [pessenergy.com](https://pessenergy.com)

 [pessenergy](https://www.instagram.com/pessenergy)

 164 Boulevard Mireille Lauze 13010 Marseille FRANCE

 [contact@pessenergy.com](mailto:contact@pessenergy.com)

 04 91 58 86 74